



SuperBus 2000 2X16 LCD Alphanumeric Touchpad Installation Instructions

466-1712 Rev. C
March 2005

Product Summary

The SuperBus® 2000 2x16 LCD (liquid crystal display) Alphanumeric Touchpad lets you control all programming and operation of a compatible security system (see the section “Specifications”). The 2-line, 16-character display provides messages to indicate the current system status.

The touchpad includes police, fire, and auxiliary panic buttons that can be activated anytime.

A built in speaker provides alarm sounds, status sounds, and button-press beeps.

Installation

Installation Guidelines

- Mount the touchpad in an environmentally controlled area 32°F to 120°F (0°C to 49°C).
- When mounting the touchpad, allow at least 4¼ inches on the left side for the Quick Guide slide-out card.
- For Concord™ Express systems, up to 4 bus devices can be connected to the panel. For Concord systems (all software versions and Concord Express version 4) up to 16 bus devices can be connected to the panel.
- For Concord systems with software versions 1.0–1.6, each bus device must have a different unit number setting to operate correctly. The touchpad unit number is factory set to 001. For Concord panels with software version 2.0 or later and Concord Express panels, bus unit numbers are assigned automatically.
- Table 1 describes the power used by the touchpad.

Table 1. Touchpad Power Usage

Current (mA)	Condition
90	Maximum alarm current
57	Typical operation
12	Standby current (no AC power)

- Do not exceed the maximum available power when using panel power for bus devices and hardwire detectors (see the specific panel *Installation Instructions* for maximum available power).
- Table 2 describes the maximum wire lengths allowed between the touchpad and panel.

Table 2. Maximum Touchpad Wire Lengths

Wire Gauge (Unshielded or Shielded)	Maximum Wire Length Between Touchpad and Panel
18	750 feet
22	300 feet

Tools and Equipment Needed

- 4-conductor, 22- or 18-gauge wire
- Screwdriver
- Drill/bits
- #6 screws and anchors (included)
- Panhead screws for a gang box installation
- Saw or utility knife for cutting wallboard

Installing the Mounting Plate

The touchpad can be installed on a wall or electrical gang box, either single- or dual-gang.

1. Separate the mounting plate from the touchpad by pressing the tab at the bottom and sliding the mounting plate down (see Figure 1).

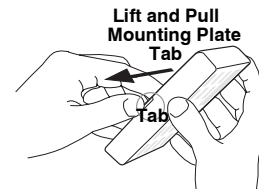

Figure 1. Separating Touchpad From Mounting Plate

2. Place the mounting plate on the wall and mark the four mounting holes (see Figure 2). Be sure to leave a 4¼-inch clearance on the left side to allow for the Quick Guide slide-out card.

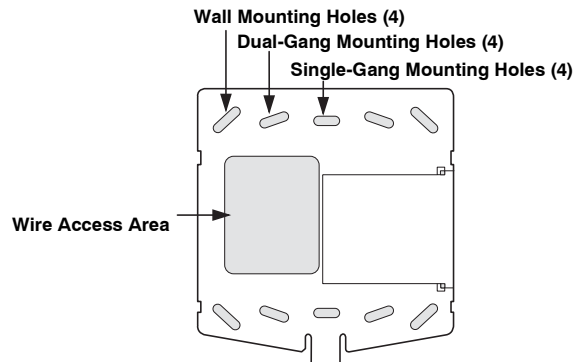

Figure 2. Mounting Holes

3. Insert anchors at the marked locations where studs are not present.
4. Looking at the back side of the mounting plate, turn it so the tab is on the left (see A in Figure 3) and position the Quick Guide slide-out card into the slots on back of the mounting plate as shown in Figure 3 (A). Make sure the card is unfolded and the “Zones” section is facing you.
5. Slide the card in the direction of the arrow in Figure 3 (A) until it snaps into the position shown in Figure 3 (B)

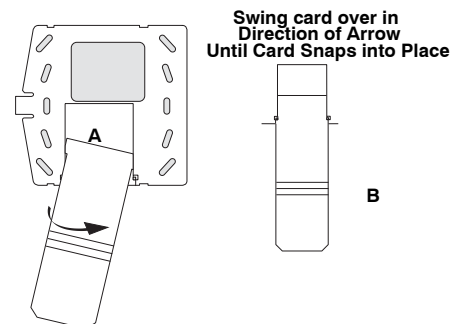

Figure 3. Inserting the Quick Guide Slide-Out Card

6. Position the mounting plate in its normal mounting position (tab at the bottom) and fold the card toward you at all three scored lines. The “Zones” section should be facing you and the folds should create a tab to slide the card in and out.
7. Align the mounting plate wall-mount holes with the wall anchors and secure the back-plate to the wall using the screws provided.
OR
If installing the back-plate on an electrical gang box, line up the appropriate gang box holes on the mounting plate with the gang box holes and secure the back-plate to the gang box using the screws provided.



Do not overtighten screws or the back plate may bend and prevent the touchpad from mounting properly.

8. For wall-mounted installations, cut a hole in the wall in the wire access area of the mounting plate to pull your cable through for wiring.

Wiring

Wiring consists of connecting the touchpad to the panel terminals.

1. Disconnect the panel transformer and backup battery.
2. Run a 4-conductor, 18- to 22-gauge wire from the panel to the touchpad location.
3. Splice the 4-conductor cable wires to the red, black, green, and white wires located on the back of the touchpad.
4. Connect the touchpad wiring to the panel terminals as shown in Figure 4.

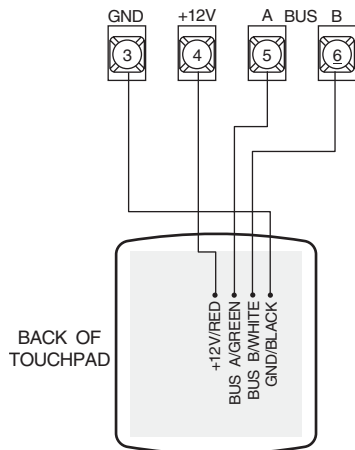

Figure 4. Wiring Touchpad to Panel Terminals

Attaching the Touchpad to the Mounting Plate

Align the four slots on the touchpad with the four tabs on the mounting plate and slide the keypad down until you hear the latch on the mounting plate click into place.

Power Up

After making all wiring connections from the touchpad to the panel, you are ready to power up the panel. Upon power up, the panel scans the bus for connected devices and automatically learns the unit number of each bus device.

Note: If you plan on installing systems with no alphanumeric touchpads, it is recommended that you keep an alphanumeric touchpad with you, specifically for programming. This touchpad can be quickly connected and disconnected from the header pins on the lower portion of the panel circuit board, as described later in this document.

To power up the panel and verify bus communication:

1. Verify that all wiring between the panel and touchpad is correct.

Note: If the touchpad does not display the date and time, see “Troubleshooting.”

2. Connect the panel battery and plug in the panel transformer. Alphanumeric touchpads should show a date and time display.

Connecting the Touchpad for System Programming Only

For installations that don’t include an alphanumeric touchpad as a permanent part of the system, you can connect one for system programming to the Programming Touchpad Header on the panel.

To do this you must first connect a Programming Touchpad Cable (60-791) to the touchpad wires (see *Programming Touchpad Cable Installation Instructions—466-1604*, included with the cable). Then, use the appropriate procedure for connecting the touchpad.

To connect a programming touchpad to a Concord Express or Concord panel with software version 2.0 or later:

1. With the panel powered up, connect the cable to the Programming Touchpad Header (see Figure 5).

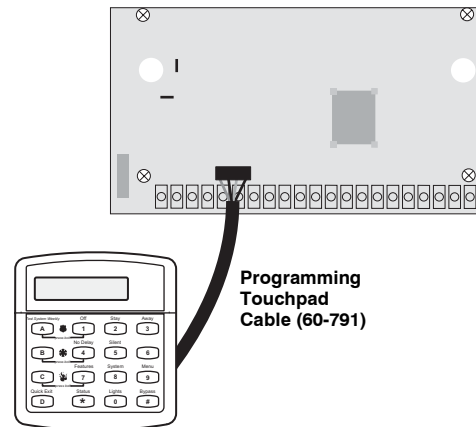

Figure 5. Connecting a Programming Touchpad

2. Activate the service touchpad by pressing $\text{[8]} + \text{[C][0][0][E]} + \text{[0]} + \text{[2]}$.
3. Enter program mode by pressing $\text{[8]} + \text{installer/dealer [C][0][0][E]} + \text{[0]} + \text{[0]}$ and program the panel using the panel *Installation Instructions*.
4. When programming is completed, simply disconnect the programming touchpad.

To connect a programming touchpad to a Concord panel with software versions 1.0–1.6:

1. Disconnect AC and backup battery power.

2. Connect the cable plug to the panel Programming Touchpad Header pins (see Figure 5).
3. Reconnect the AC and backup battery power. The touchpad briefly displays *****
SCANNING BUS DEVICES, then shows a time and date display.

Note: If the touchpad does not respond as described in step 3, there may be a bus conflict. To correct this, change the touchpad unit number as described in the section "Changing the Touchpad Unit Number."

Removing the programming touchpad from Concord panels with software versions 1.0–1.6:

To prevent a trouble condition, you must delete the programming touchpad unit number from Concord panel memory *before* disconnecting it.

1. After programming is completed, return to the *ACCESSORY MODULES* menu, then press **[F]**. The display should read *BUS DEVICES*.
2. Press **[F]**. The display shows the lowest unit number and its device name.
3. Press **[A]** or **[B]** until the display shows the programming touchpad unit number.
4. Press **[D]** to delete the device and its unit number from panel memory. The display shows:
UNIT - TYPE
14-NONE
5. Exit program mode and disconnect the programming cable from the panel header.

Testing



Contact the Central Monitoring Station before activating any alarms, to avoid dispatching local police and fire departments.

Test the touchpad by arming/disarming the system, activating the touchpad panics, bypassing sensors, and by turning chime and lights on/off to verify correct operation. Refer to the panel *Owner's Manual* for system operating instructions.

Adjusting Display

The touchpad display can be adjusted for easier viewing to help compensate for lighting conditions in the touchpad location.

The brightness adjustment lightens or darkens the background. The contrast adjustment lightens or darkens the text.

To adjust display brightness:

1. Enter user programming mode by pressing **[U] + user, partition, or system master [Q][O][R][E]**. The display shows *SYSTEM MENU*, then *TIME AND DATE* (Concord panels with software versions 1.0–1.6 display *USER CODES*.)
2. Press **[B]** until the display shows *OPTIONS*, then press **[F]**. The display shows *DOWNLOADING ON/OFF (current setting)*.
3. Press **[B]** until the display shows *TOUCHPAD BRIGHTNESS 2* (default setting).
4. Enter a setting from **0** (darkest background) to **3** (brightest background), then press **[F]**.

5. The display flashes the entered selection, then stops after pressing **[F]** and displays the new setting and brightness level.
6. Exit user programming mode by entering:

[*] + [0] + [0] + [F] for Concord panels with software versions 2.0 or later

or

[*] + [7] + [F] for Concord panels with software versions 1.0–1.6.

To adjust display contrast:

1. Enter configuration mode by pressing the **[D]** and **[B]** buttons together for at least two seconds. The display shows *DA nnn*.
2. Press and release the **[1]** and **[2]** buttons together repeatedly, until the desired contrast level is displayed.
3. Press **[*]** and the display briefly shows *DONE*, then shows the time and date.

Troubleshooting

Table 3 describes what to do if the touchpad does not operate correctly.

Table 3. Troubleshooting

Problem	Action/Solution
Touchpad doesn't power up (no display and no beeps when buttons are pressed).	<ul style="list-style-type: none"> • Check for correct wiring connections at touchpad and panel terminals. • Make sure panel battery is connected correctly and that the panel transformer is plugged in. • Make sure panel transformer is not plugged into an electrical outlet controlled by a switch. Relocate transformer to an unswitched outlet location, if necessary.
Touchpad display appears blank, but beeps sound when buttons are pressed.	<ul style="list-style-type: none"> • Check the touchpad display contrast setting. It may be set to 0 (no display).
Touchpad display shows a flashing *, indicating a trouble condition and system doesn't respond to commands from touchpad.	<ul style="list-style-type: none"> • Check for correct bus wiring connections (green and white wires) at touchpad and panel terminals. • Make sure touchpad unit number is set to a different number than all other bus devices. If necessary, change the touchpad unit number (see procedure on this page). (Concord panels with software versions 1.0-1.6 only.) • Make sure touchpad is learned into panel.

Changing the Touchpad Unit Number (Concord Panels with Software Version 1.0-1.6 Only)

Use the following guidelines when changing device unit numbers to avoid communication conflicts between bus devices and the panel:

- All bus devices with DIP switches (LED Touchpads, ESMs, HIMs, etc.) must be set to the desired unit number before applying power and entering program mode.
- Whenever possible, assign touchpad unit numbers before all other panel programming.

To change the touchpad unit number:

1. At the touchpad, press and hold the **[D]** and **[B]** buttons together for at least 2 seconds. The display should show *DA n*, where *n* is the touchpad current unit number (000 - 015).

Note: At this time, the touchpad is in configuration mode and no longer communicating to the panel. The system may immediately indicate a bus failure. Ignore the failure and continue with the procedure. The bus failure will clear after successfully changing the touchpad unit number.

2. Press **ENTER**. The display shows *ENTER* _.
3. Enter the desired three digit unit number (000 - 015), then press **ENTER**. The display shows *DA n*, where *n* is the new touchpad unit number.

Note: Do not use unit number 15 in Concord RF systems.

4. Press **EXIT** to exit from the configuration mode.

Note: If the new touchpad unit number was previously learned by the panel, communication between the touchpad and the panel begins immediately. However, if the new touchpad unit number has never been learned by the panel, continue with step five.

5. Force the panel to scan bus devices as follows:
 - For systems where this is the only installed touchpad, remove panel AC and battery power, then re-apply power.
 - For systems with more than one touchpad, go to another system touchpad and enter **8 + installer/dealer** **[C][D][E] + [0] + [1]**. The display shows *SCANNING BUS DEVICES*, then a time and date display.

The touchpad and all other bus devices should operate correctly and any bus failures should be cleared.

Note: If the panel still indicates a bus failure the panel may have previously learned a unit number that is no longer used by any bus device. See the specific panel *Installation Instructions* for more information on deleting unused unit numbers.

Specifications

Compatibility	Concord, Concord 4, Concord Express, Concord Express 4 and Concord Ultra Panels
Power Requirements	12 VDC nominal (see Table 1 for more information)
Operating Temperature	32° to 120°F (0° to 49°C)
Humidity	70% relative, non-condensing
Dimensions	5.0" x 4.5" x .75" (L x W x D)
Installation	Wall mount

Listings

- UL 985 Household Fire Warning System Units
- UL 1023 Household Burglar-Alarm System Units
- UL1610 Central Station Burglar-Alarm Units (Commercial Burglary)

Note: See specific panel *Installation Instructions* for complete UL installation requirements for the system you are installing.

Notices

FCC Part 15 Information to the User

Changes or modifications not expressly approved by GE Security can void the user's authority to operate the equipment.

FCC Part 15 Class A

This equipment has been tested and found to comply with the limits for a class A digital device, pursuant to part 15 of the FCC rules. These limits are designed to provide reasonable protection against harmful interference when the equipment is operated in a commercial environment.

This equipment generates, uses and can radiate radio frequency energy and, if not installed and used in accordance with the instruction manual, may cause harmful interference to radio communications. Operation of this equipment in a residential area is likely to cause harmful interference in which case users will be required to correct the interference at their own expense.

FCC Part 15 Class B

This equipment has been tested and found to comply with the limits for a class B digital device, pursuant to part 15 of the FCC rules. These limits are designed to provide reasonable protection against interference in a residential environment.

This equipment generates, uses and can radiate radio frequency energy and, if not installed and used in accordance with the instruction manual, may cause harmful interference to radio communications. However, there is no guarantee that interference will not occur in a particular installation.

If this equipment does cause harmful interference to radio or television reception, which can be determined by turning the equipment off an on, the user is encouraged to try to correct the interference by one or more of the following measures:

- Reorient or relocate the receiving antenna
- Increase the separation between the equipment and receiver
- Connect the affected equipment and the panel receiver to separate outlets, on different branch circuits
- Consult the dealer or an experienced radio/TV technician for help